

LV8400V — Bi-CMOS IC Forward/Reverse Motor Driver

Overview

The LV8400V is a 1-channel motor driver IC using D-MOS FET for output stage and is able to control 4 modes of forward, reverse, brake, and standby.

As the P/N-channel structure is used in the H-bridge output stage, the LV8400V features minimal number of external component and low on-resistance (0.33Ω typical). This IC is optimal for driving motors that requires high current.

Functions

- 1-channel forward/reverse motor driver
- Low power consumption
- Low output ON resistance 0.33Ω
- Built-in constant current output circuit
- Built-in low voltage reset and thermal shutdown circuit
- Four mode function forward/reverse, brake, standby

Typical Applications

- Digital single-lens reflex camera
- POS Printer

Pin Assignment

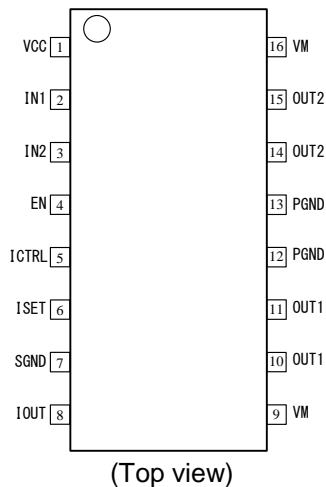

Package Dimensions

Unit : mm(typ)

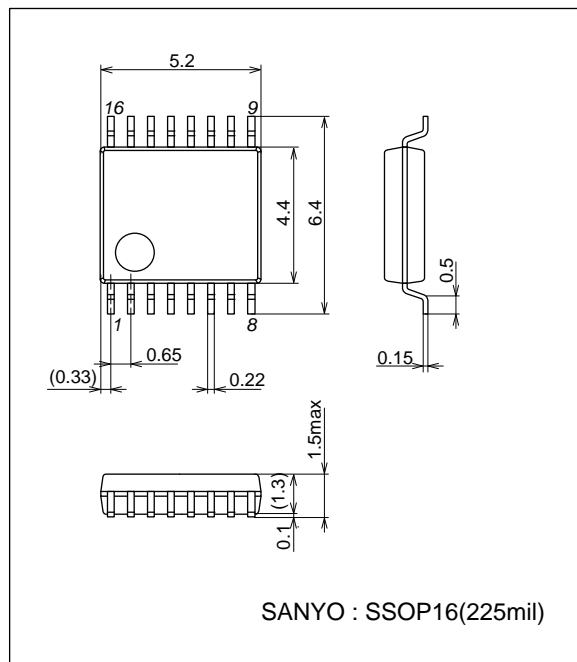

Mounting pad sketch

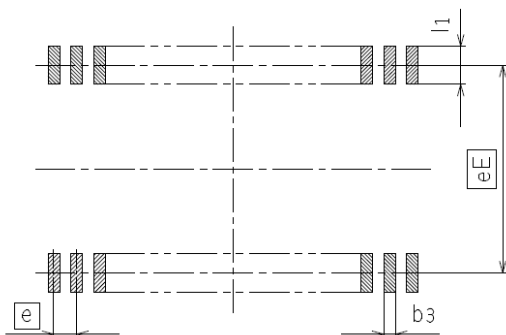

(Unit : mm)

Reference Symbol	SSOP30(225mil)
eE	5.80
e	0.65
b3	0.32
l1	1.00

Caution: The package dimension is a reference value, which is not a guaranteed value.

LV8400V

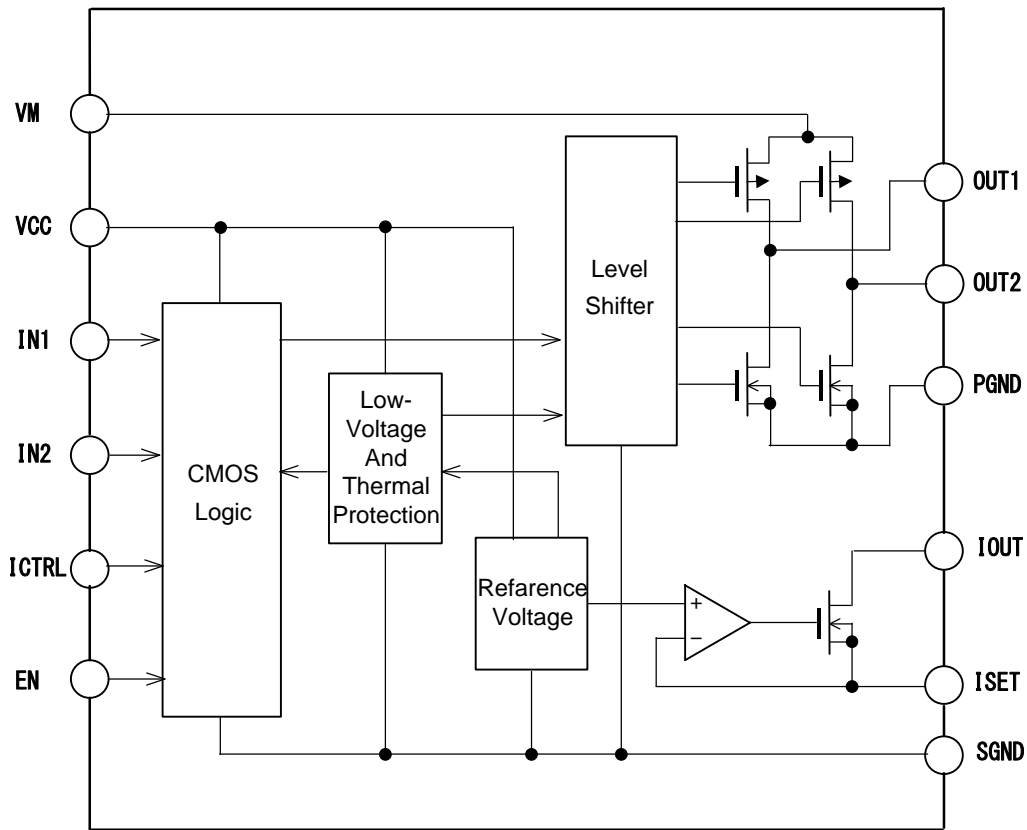

Figure 1. Block Diagram

Specifications

Maximum Ratings at $T_a=25^\circ\text{C}$, $\text{SGND}=\text{PGND}=0\text{V}$

Parameter	Symbol	Conditions	Ratings	Unit
Power supply voltage (for load)	V_M max		-0.5 to 16.0	V
Power supply voltage (for control)	V_{CC} max		-0.5 to 6.0	V
Output current	I_O max	DC	1.2	A
	I_O peak1	$t \leq 100\text{ms}$, $f = 5\text{Hz}$	2.0	A
	I_O peak2	$t \leq 10\text{ms}$, $f = 5\text{Hz}$	3.8	A
	I_{OUT} max	DC	30	mA
Input voltage	V_{IN} max		-0.5 to $V_{CC}+0.5$	V
Allowable power dissipation	P_d max	Mounted on a specified board *	800	mW
Operating temperature	T_{opr}		-20 to +75	$^\circ\text{C}$
Storage temperature	T_{stg}		-55 to +150	$^\circ\text{C}$

* Specified board : 30mm × 50mm × 1.6mm, glass epoxy board.

Allowable Operating Conditions at $T_a=25^\circ\text{C}$, $\text{SGND}=\text{PGN}=0\text{V}$

Parameter	Symbol	Conditions	Ratings	Unit
Power supply voltage (for load)	V_M		4.0 to 15.0	V
Power supply voltage (for control)	V_{CC}		2.7 to 5.5	V
Input signal voltage	V_{IN}		0 to V_{CC}	V
Input signal frequency	f max	Duty = 50%	200	kHz

LV8400V

Electrical Characteristics Ta=25°C, VCC=5.0V, VM =12.0V, SGND=PGND=0V, unless otherwise specified.

Parameter	Symbol	Conditions	Remarks	Ratings			Unit
				min	typ	max	
Standby load current drain 1	IMO1	EN = 0V	1			1.0	μA
Standby load current drain 2	IMO2	EN = 0V, VCC = 0V, Each input pin = 0V	1			1.0	μA
Standby control current drain	ICO	EN = 0V, IN1 = IN2 = 0V	2			1.0	μA
Operating load current drain 1	IM1	VCC = 3.3V, EN = 3.3V	3		0.35	0.70	mA
Operating load current drain 2	IM2	VCC = 5.0V, EN = 5.0V	3		0.35	0.70	mA
Operating current consumption 1	IC1	VCC = 3.3V, EN = 3.3V	4		0.6	1.2	mA
Operating current consumption 2	IC2	VCC = 5.0V, EN = 5.0V	4		0.8	1.6	mA
High-level input voltage	VIH	2.7 ≤ VCC ≤ 5.5V		0.6× VCC		VCC	V
Low-level input voltage	VIL	2.7 ≤ VCC ≤ 5.5V		0		0.2× VCC	V
High-level input current (EN, IN1, IN2, ICTRL)	I _{IH}	V _{IN} = 5V	5	12.5	25	50	μA
Low-level input current (EN, IN1, IN2, ICTRL)	I _{IL}	V _{IN} = 0V	5	-1.0			μA
Pull-down resistance value (EN, IN1, IN2, ICTRL)	R _{DN}			100	200	400	kΩ
Output ON resistance	R _{ON}	Sum of top and bottom sides ON resistance. 2.7V ≤ VCC ≤ 5.5V	6		0.33	0.5	Ω
Constant current output leakage current	I _O LEAK	EN = 0V	7			1.0	μA
Output constant current	I _{OUT}	RSET = 40Ω, Internal reference = 0.2V	8	4.65	5.00	5.35	mA
ISET pin voltage	V _{ISET}	RSET = 40Ω	9	0.186	0.20	0.214	V
Constant current output ON resistance	R _{ONIO}	RSET = 0Ω, I _O = 5mA	10		20	30	Ω
Low-voltage detection voltage	VCS	VCC voltage	11	2.10	2.25	2.40	V
Thermal shutdown temperature	T _{th}	Design guarantee *	12	150	180	210	°C
Output block	Turn-on time	T _{PLH}	13		0.5	1.0	μs
	Turn-off time	T _{PHL}	13		0.5	1.0	μs

* Design guarantee value and no measurement is performed.

Remarks

1. Current consumption when output of the VM pin is off.
2. Current consumption at the VCC pin when all functions are stopped.
3. Current consumption of the VM pin when EN is high.
4. Current consumption of the VCC pin when EN is high.
5. These input pins (EN, IN1, IN2, and ICTRL) have an internal pull-down resistor.
6. Sum of the upper and lower side output on resistance.
7. Leakage current when the constant current output is off.
8. Current value that is determined by dividing the internal reference voltage (0.2V) by RSET.
9. ISET pin voltage when the constant current output block is active.
10. ON resistance value of the constant current output block.
11. All output transistors are turned off if a low-voltage is detected.
12. All output transistors are turned off if the thermal protection circuit is activated. They are turned on again as the temperature decreases.
13. Rising time from 10 to 90% and falling time from 90 to 10% are specified.

LV8400V

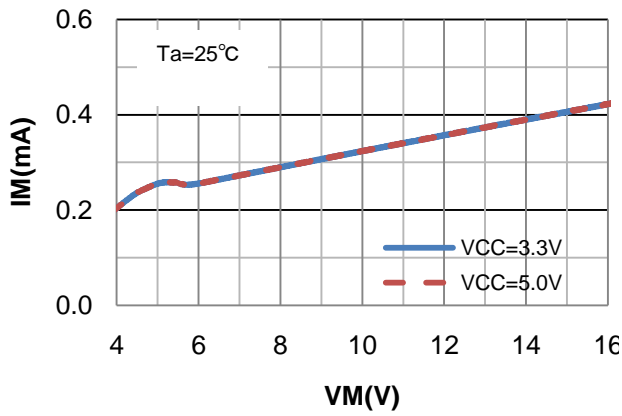

Figure 2. VM current drain vs. VM supply voltage

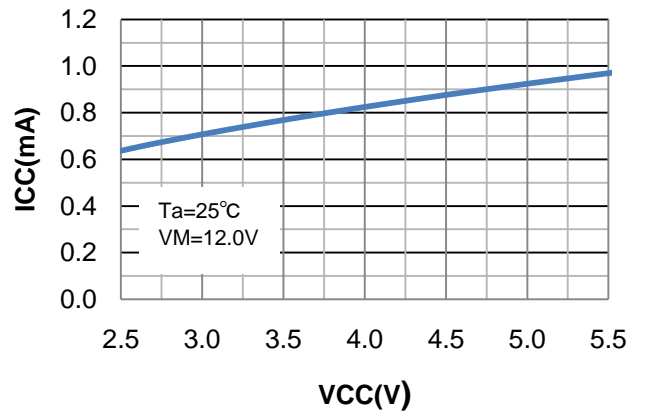

Figure 3. VCC current drain vs. VCC supply voltage

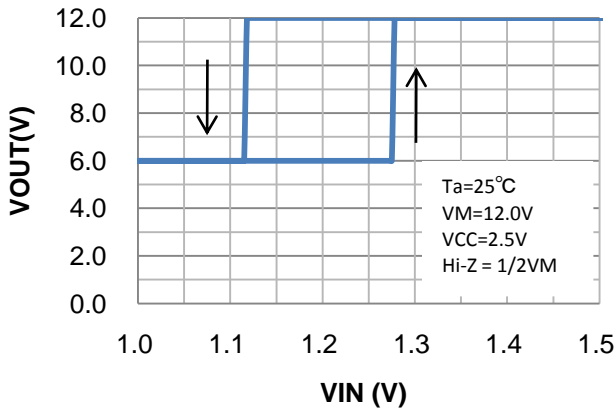

Figure 4. Output voltage vs. Input voltage

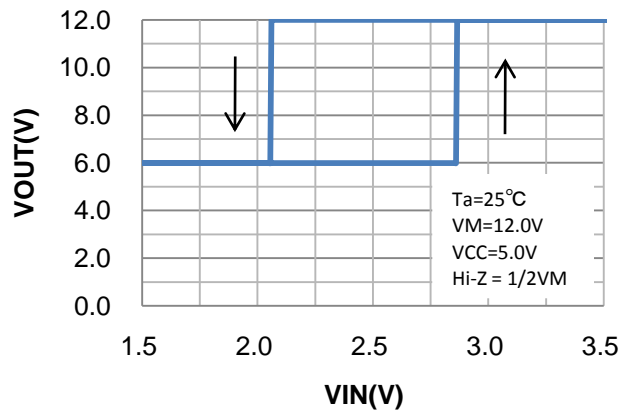

Figure 5. Output voltage vs. Input voltage

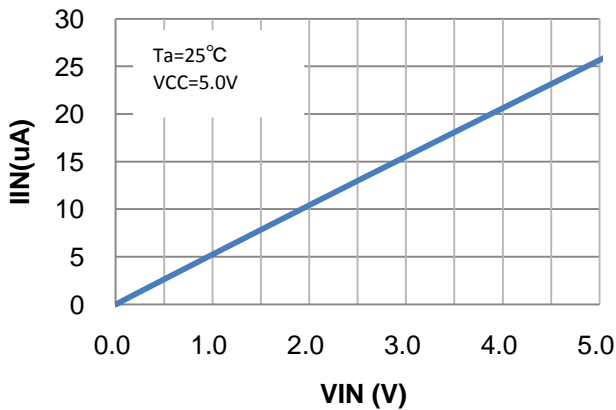

Figure 6. Input current vs. Input voltage

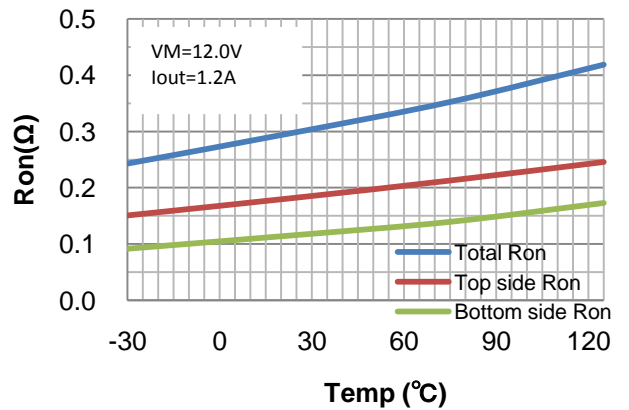

Figure 7. Output on-resistance vs. Temperature

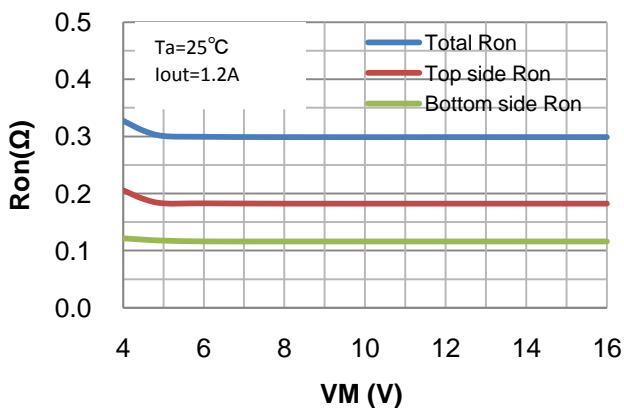

Figure 8. Output on-resistance vs. VM supply voltage

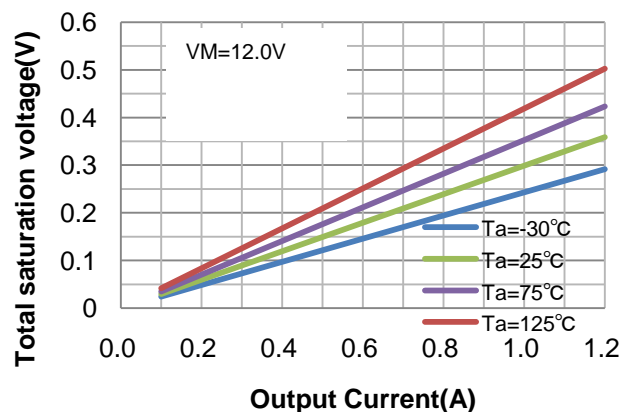

Figure 9. Saturation voltage vs. Output current

LV8400V

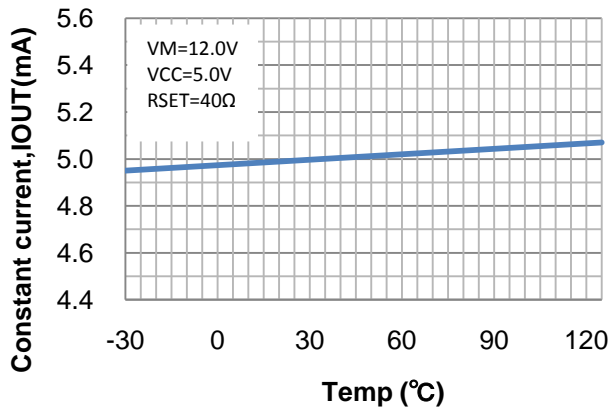

Figure 10. Constant current, IOOUT vs. Temperature

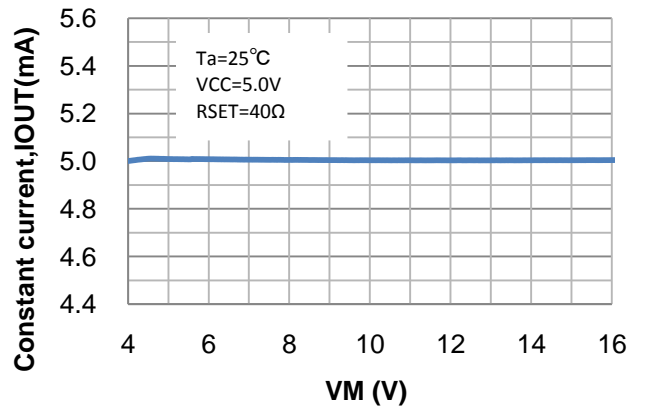

Figure 11. Constant current, IOOUT vs. VM supply voltage

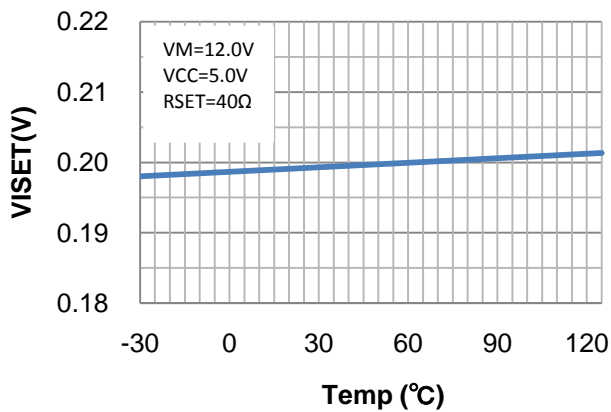

Figure 12. VISET voltage vs. Temperature

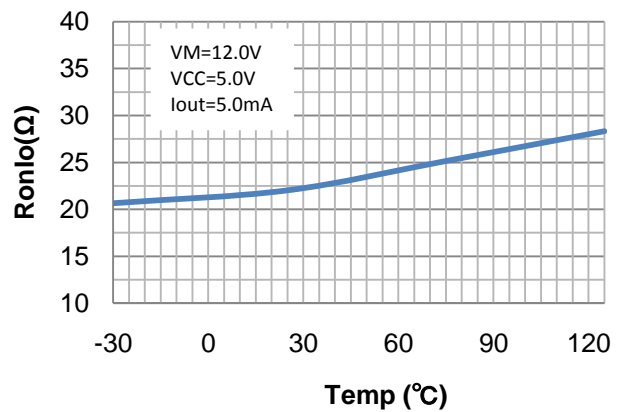

Figure 13. IOOUT on-resistance vs. Temperature

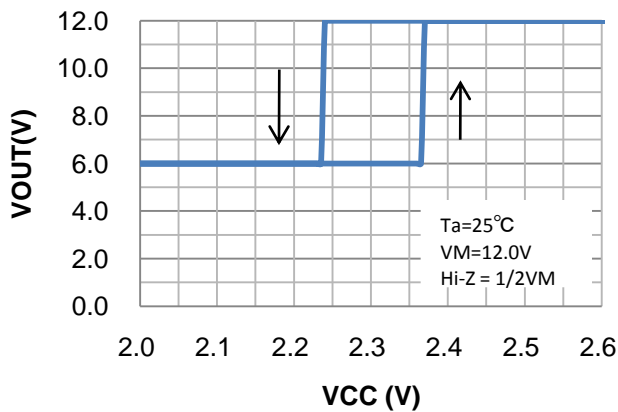

Figure 14. VCC low voltage reset characteristic

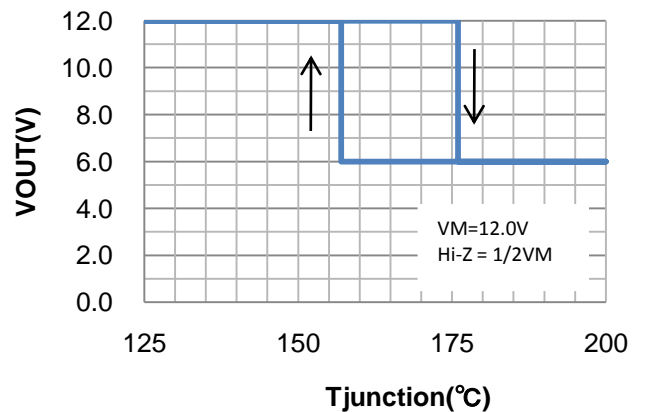

Figure 15. Thermal shutdown characteristic

LV8400V

Pin Functions

Pin No.	Pin name	Description	Equivalent circuit
9 16	VM	Motor block power supply. (Both pins must be connected) The applicable voltage range is 4.0V to 15.0V. Make sure to connect a bypass capacitor between VM (pin 9 and 16) and PGND (pin 12 and 13) respectively to stabilize power line of VM.	
1	VCC	Logic block power supply. The applicable voltage range is 2.7V to 5.5V. Make sure to connect a bypass capacitor between VCC (pin 1) and SGND (pin 7) to stabilize power line of VM.	
4	EN	Logic enable pin. (Pull-down resistor incorporated) Standby mode is set when the voltage level is Low. Therefore, current consumption is 0. When the voltage level is High, the internal circuit is activated. Since 200KΩ of pull-down resistor is inserted, when OPEN the operation is equivalent to that of Low control signal.	
2 3 5	IN1 IN2 ICTRL	Control signal input pin Driver output switching. (Pull-down resistor incorporated) When the voltage level is High, all the outputs that correspond to inputs are activated. Since 200KΩ of pull-down resistor is inserted, when OPEN the operation is equivalent to that of Low control signal. PWM control is feasible when the input frequency is 200KHz or lower.	
10 11 14 15	OUT1 OUT2	Driver output. This pin is connected to the motor. Operation mode is determined according to the state of input pins.	

LV8400V

Pin No.	Pin name	Description	Equivalent circuit
6 8	ISET IOUT	<p>Constant current output. ON/OFF of the internal Nch MOS is determined according to the state of ICTRL.</p> <p>By connecting current sense resistor with ISET(pin 6) and SGND (pin 8), you can sink constant current from IOUT(pin 8).</p>	
7	SGND	Logic block ground.	
12 13	PGND	Drivers block ground. (Both pins must be connected)	

Operation explanation

Saturation drive H bridge

H bridge drive is integrated which enables controlling 4 modes of forward, reverse, brake, and standby.

Logic input specifications

EN	IN1	IN2	OUT1	OUT2	Mode
H	H	H	L	L	Brake
	H	L	H	L	Forward
	L	H	L	H	Reverse
	L	L	Z	Z	Standby
L	-	-	Z	Z	All function stop

EN	ICTRL	IOUT	Mode
H	H	ON	Constant current ON
	L	Z	Constant current OFF
L	-	Z	All function stop

- : denotes a don't care value. Z: High-impedance

When IN1 and IN2 are "Low", the operation of H bridge output stage is in standby mode.

When "high" is input to the input pin, the output transistor of the H bridge output stage operates and the operation shifts as follows: forward, reverse, and brake.

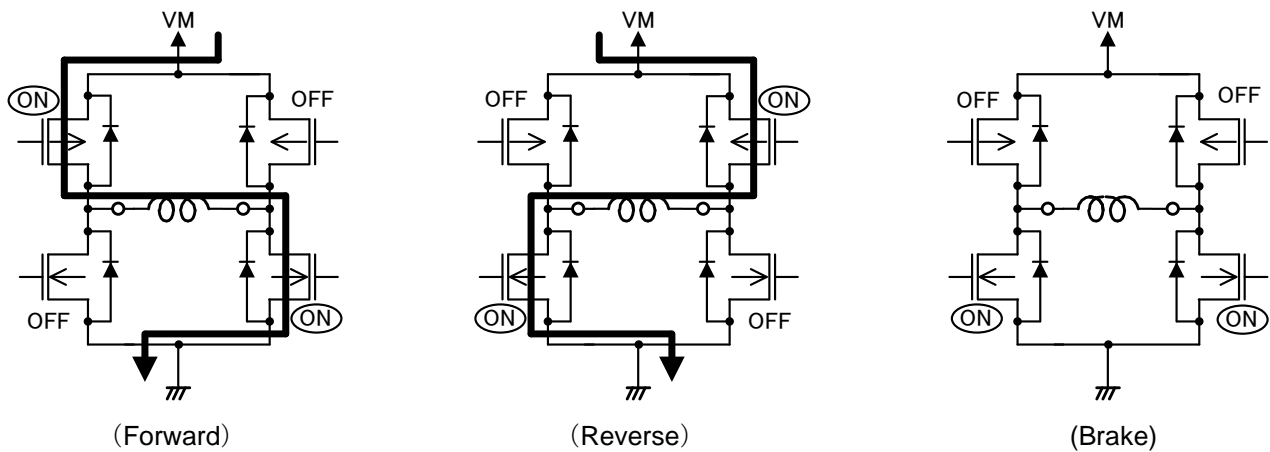

Figure 16. Output stage transistor function

- Current drain is zero in all function stop mode. (excluding the current that flows out of the EN pin)
- * All power transistors turn off and the motor stops driving when the IC is detected in low voltage or thermal protection mod

Constant current output circuit

Since you can sink constant current of 30mA at a maximum, this motor driver can be used for LED. The output constant current (IOUT) is determined by the internal reference voltage and the sense resistor between the ISET and SGND pins.

$I_{OUT} = \text{Internal reference voltage (0.2V)} \div \text{Sense resistor (RSET)}$

IOUT calculating formula

$$I_{OUT} = \frac{0.2[V]}{RSET}$$

(Ex.) Setup to IOUT=5.0[mA]

$$I_{OUT} = \frac{0.2[V]}{40\Omega} \cong 5.0[mA]$$

From the formula above, I_{OUT} = 5mA when a sense resistor of 40Ω is connected between the ISET and SGND.

Thermal shutdown function

This IC includes thermal shutdown circuit.

The thermal shutdown circuit is incorporated and the output is turned off when junction temperature T_j exceeds 180°C. As the temperature falls by hysteresis, the output turned on again (automatic restoration).

The thermal shutdown circuit does not guarantee the protection of the final product because it operates when the temperature exceed the junction temperature of T_{jmax}=150°C.

Thermal shutdown temperature = 180°C (typ)

VCC Low voltage malfunction prevention

This IC includes the function of VCC Low voltage malfunction prevention.

When the supply voltage of VCC lowers down to approximately 2.25V (typ), H bridge output stage shifts from operation mode to standby mode. On the other hand, when the supply voltage of VCC increases to approximately 2.35V, H bridge output stage shifts to operation mode.

VCC low-voltage cutoff voltage = 2.25V(typ)

Application Circuit Example

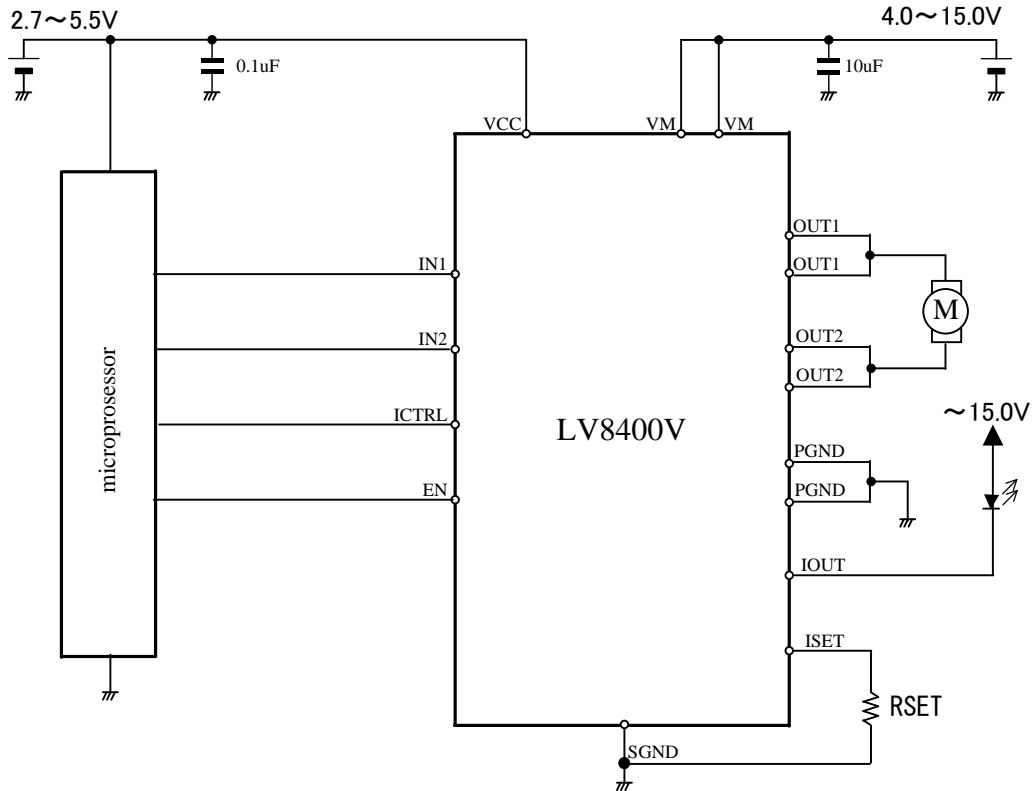

Figure 17. Sample Application Circuit

* : Connect a bypass capacitor as close as possible to the IC to absorb kickback. Characteristics of the IC may be damaged if an instantaneous voltage surge exceeds the maximum ratings in VM line due to coil kickback or other causes.

Bypass capacitor has no specific regulation on electrolytic capacitor or ceramic capacitor. However, it is recommended that the value of capacitor should be as high as possible. When capacitor with high capacitance is used, charge current to capacitor increases. Hence, caution is required for the battery's capability of current supply.

Recommendation value

- Between VM and PGND: 10uF or higher
- Between VCC and SGND: 0.1uF or higher

Operation setting of DC motor

When you drive DC motor with LV8400V, caution is required to switch motor rotation from forward to reverse because when doing so, electromotive force (EMF) is generated and in some cases, current can exceed the ratings which may lead to the destruction and malfunction of the IC .

Coil current (I_o) for each operation is obtained as follows when switching motor rotation from forward to reverse.

- Starting up motor operation:

$$\text{Coil current } I_o(A) = \frac{VM - EMF(V)}{\text{Coil resistance}(\Omega)}$$

At startup, I_o is high because EMF is 0. As the motor starts to rotate, EMF becomes higher and I_o becomes lower.

- When switching motor rotation from forward to reverse:

$$\text{Coil current } I_o(A) = \frac{VM + EMF(V)}{\text{Coil resistance}(\Omega)}$$

When EMF is nearly equal to VCC at a max, make sure that the current does not exceed I_{omax} since a current which is about double the startup current may flow at reverse brake.

- Brake:

$$\text{Coil current } I_o(A) = \frac{EMF(V)}{\text{Coil resistance}(\Omega)}$$

Since EMF is 0 when the rotation of motor stops, I_o is 0 as well.

CW(Forward) - CCW(Reverse)

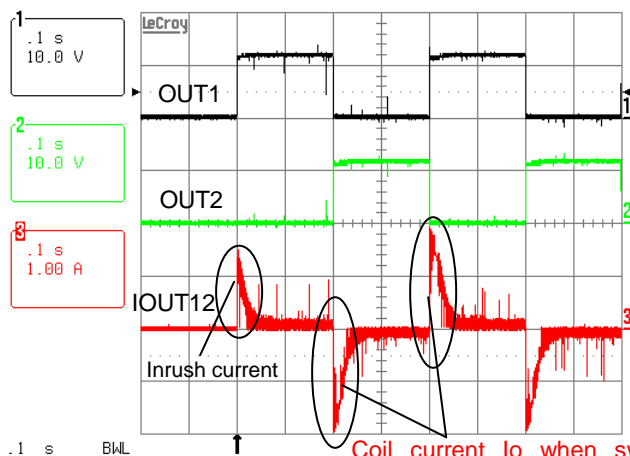
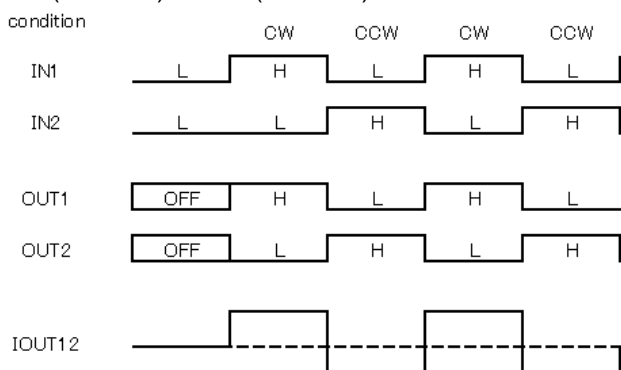

CW(Forward) - Brake

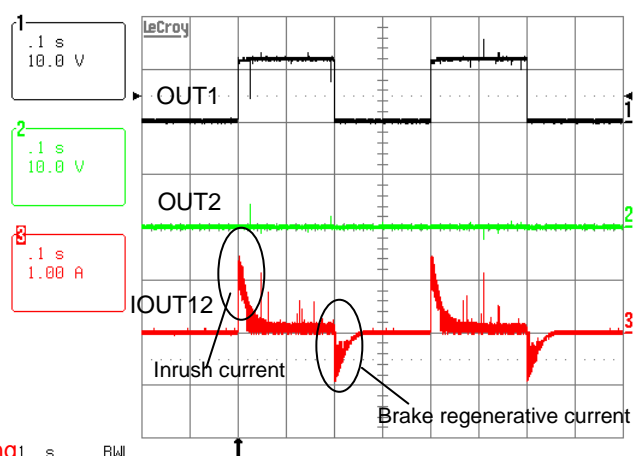
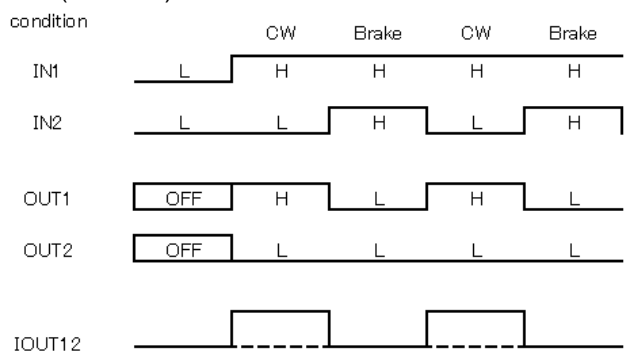

Coil current I_o when switching
from forward to reverse

Figure 18. Driving waveform of DC motor

When you switch motor rotation from forward to reverse, if I_o is higher than I_{omax} , you can operate short brake mode between forward and reverse either to slow down or stop the motor.

LV8400V

Input and output characteristics of H-Bridge

LV8400V can be driven by direct PWM control of H-Bridge by inputting PWM signal to IN.

However output response of H-Bridge worsens around On-duty 0%, which generates dead zone. As a result, IC control loses lineality.

If you intend to drive motor in such control range, make sure to check the operation of your motor.

Input-Output Characteristics of H-Bridge (reference data)

Forward/Reverse ⇔ Brake

VM=12.0V

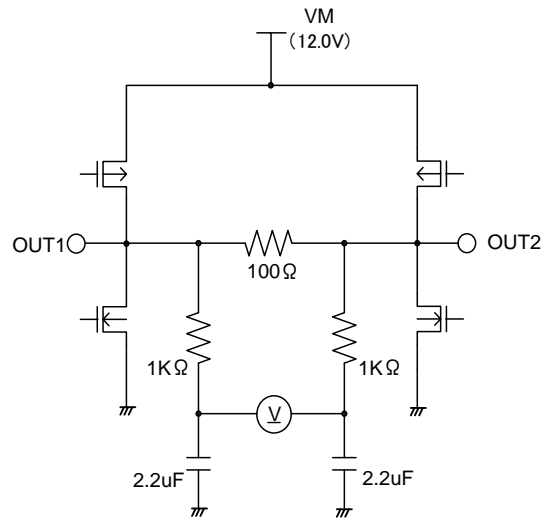

Figure 19.Measurement connection diagram

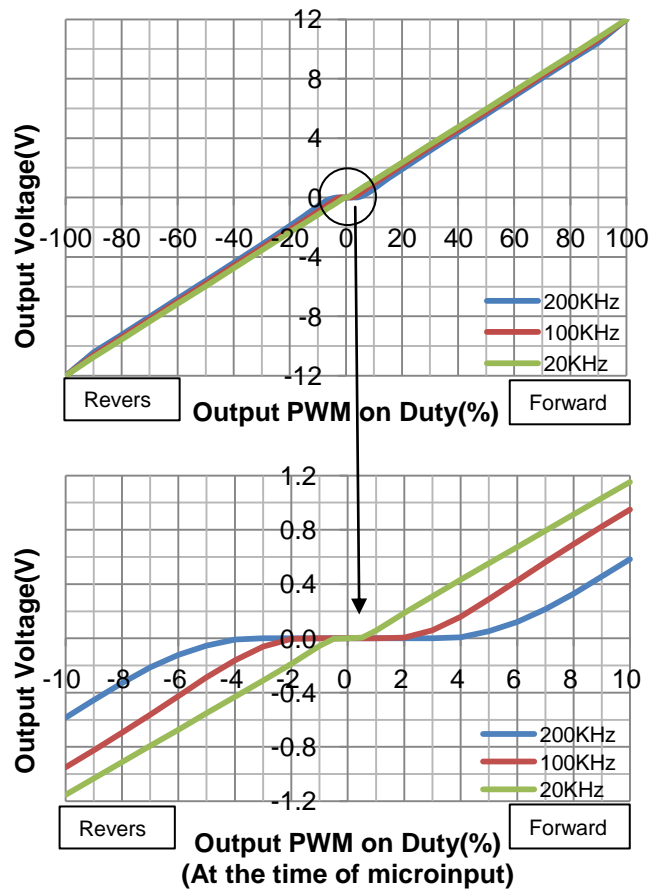
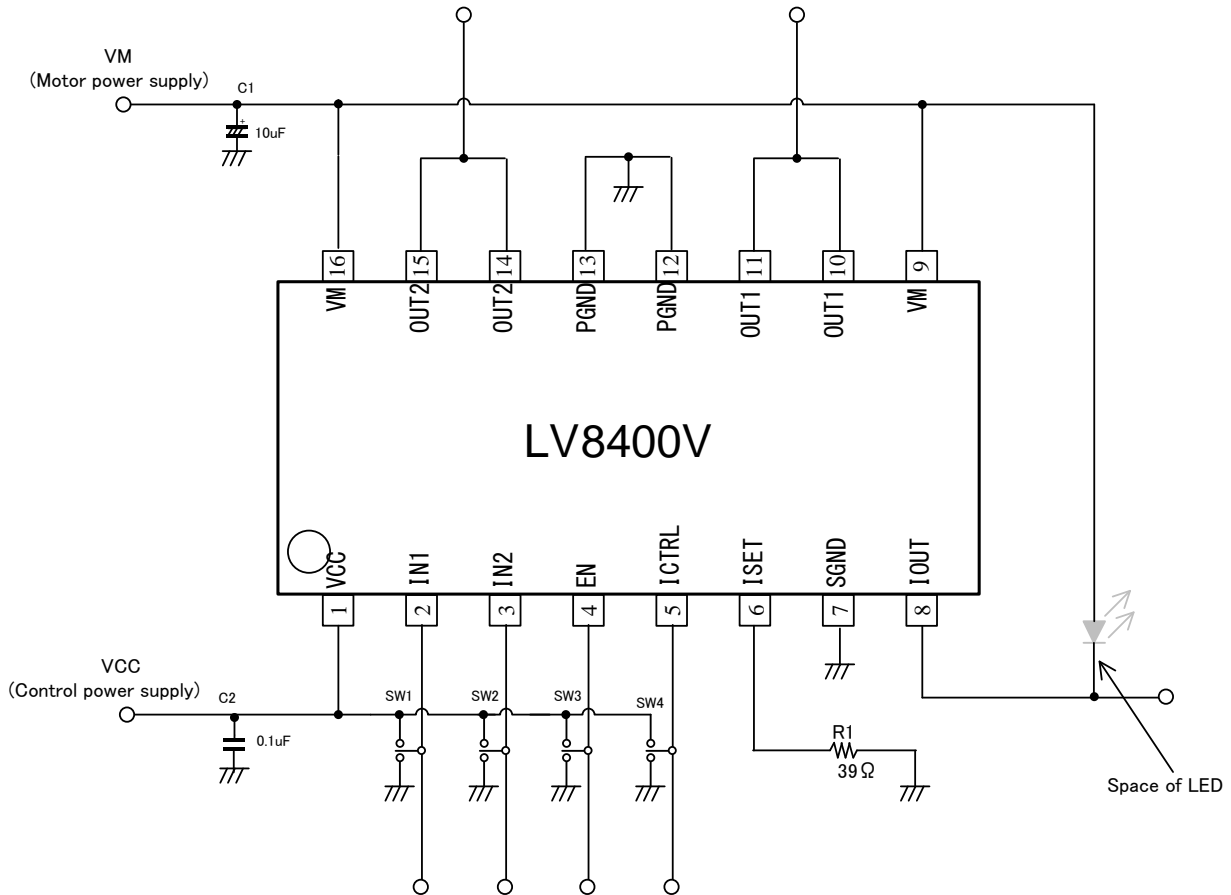

Figure 20. Input and Output Characteristics of H-Bridge

LV8400V

Evaluation Board Manual

1. Evaluation Board circuit diagram



Bill of Materials for LV8400V Evaluation Board

Designator	Qty	Description	Value	Tol	Footprint	Manufacturer	Manufacturer Part Number	Substitution Allowed	Lead Free
IC1	1	Motor Driver			SSOP16 (225mil)	SANYO semiconductor	LV8400V	No	Yes
C1	1	VM Bypass capacitor	10µF 50V	20%	F2.0-5	SUN Electronic Industries	50ME10HC	Yes	Yes
C2	1	VCC Bypass capacitor	0.1µF 100V	10%	1608	Murata	GRM188R72A 104KA35D	Yes	Yes
R1	1	Sense resistor	39Ω 1W	5%	1608	KOA	RK73B1JT390 J	Yes	Yes
LED	1							Yes	
SW1-SW4	4	Switch				MIYAMA	MS-621-A01	Yes	Yes
TP1-TP8	8	Test points				MAC8	ST-1-3	Yes	Yes

LV8400V

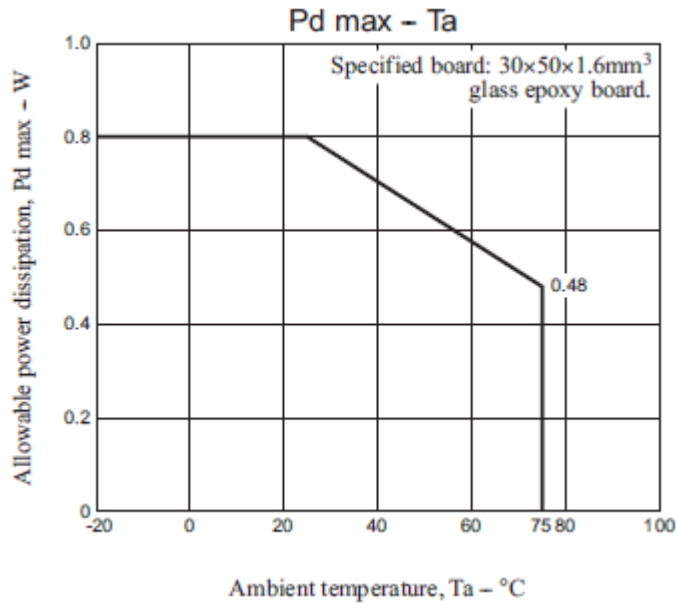

Evaluation Board PCB Design

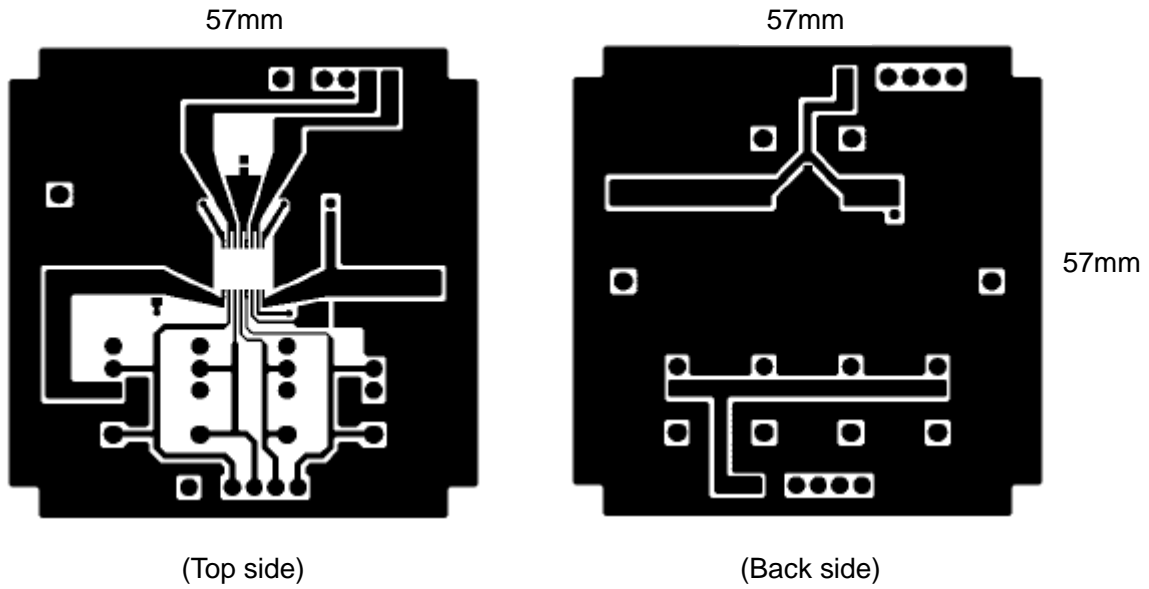

LV8400V

2. DC motor drive

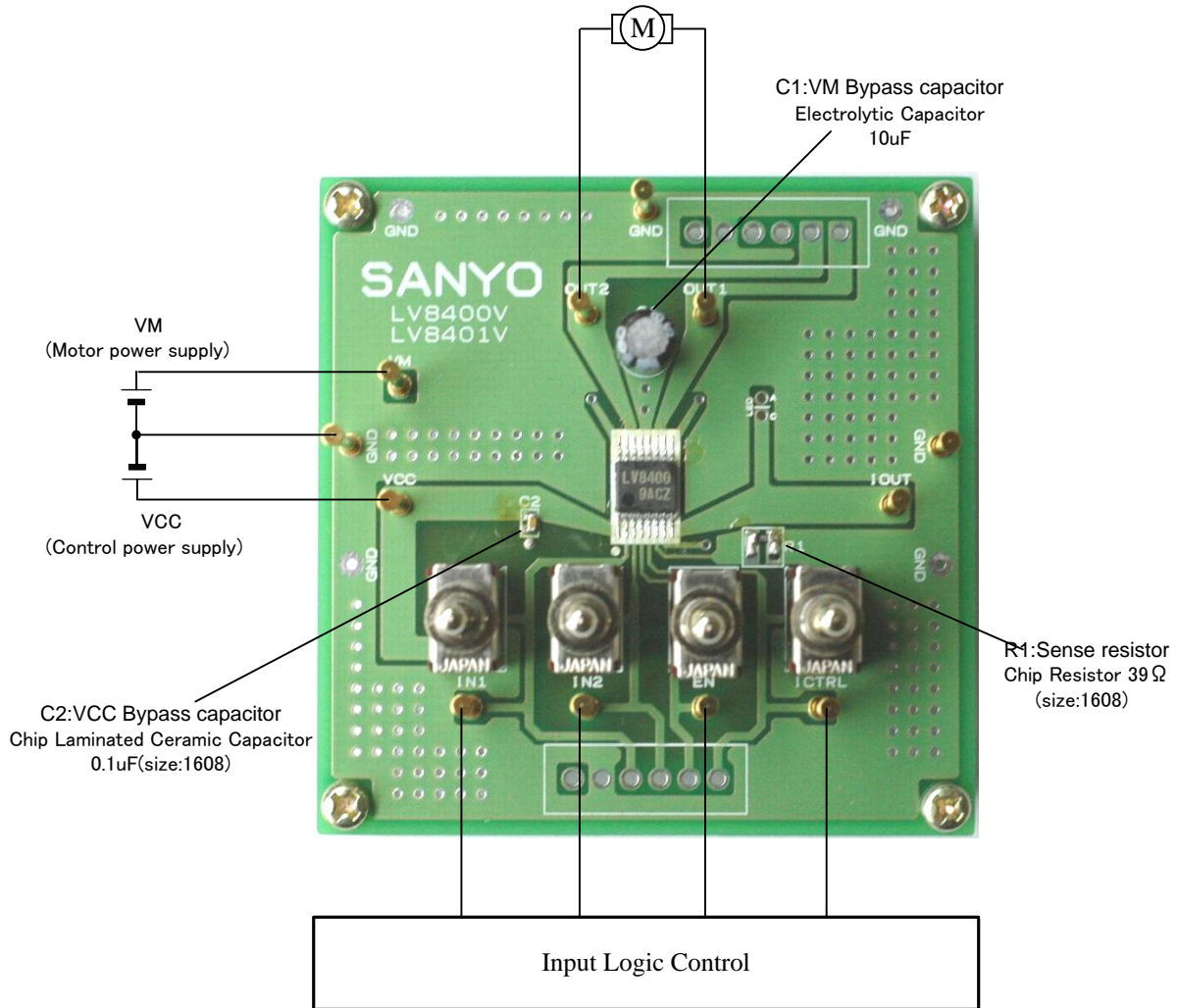

- Connect a DC motor with OUT1 and OUT2.
- Connect the motor power supply with the terminal VM, the control power supply with the terminal VCC. Connect the GND line with the terminal GND.
- You can drive DC motor by setting EN=High and switching the input signal as follows.

EN	IN1	IN2	OUT1	OUT2	Mode
H	H	H	L	L	Brake
	H	L	H	L	Forward
	L	H	L	H	Reverse
	L	L	Z	Z	Standby
L	-	-	Z	Z	All function stop

When you drive DC motor with LV8400V, caution is required to switch motor rotation from forward to reverse because when doing so, electromotive force (EMF) is generated and in some cases, current can exceed the ratings which may lead to the destruction and malfunction of the IC .
See p.11 for the further details.

- By setting ICTRL to High, constant current output circuit operates.

Since you can sink the constant current of 30mA at a maximum, this IC can be used for LED.

The output constant current (I_{OUT}) is determined by the internal reference voltage and the sense resistor between the ISET and SGND pins.

I_{OUT} = Internal reference voltage (0.2V) ÷ Sense resistor (RSET)

IOUT calculating formula

$$I_{OUT} = \frac{0.2[V]}{RSET}$$

(Ex.) Setup to $I_{OUT}=5.0[mA]$

$$I_{OUT} = \frac{0.2[V]}{40\Omega} \cong 5.0[mA]$$

If necessary, please use LED to confirm the operation of the IC.

- Any and all SANYO Semiconductor Co.,Ltd. products described or contained herein are, with regard to "standard application", intended for the use as general electronics equipment (home appliances, AV equipment, communication device, office equipment, industrial equipment etc.). The products mentioned herein shall not be intended for use for any "special application" (medical equipment whose purpose is to sustain life, aerospace instrument, nuclear control device, burning appliances, transportation machine, traffic signal system, safety equipment etc.) that shall require extremely high level of reliability and can directly threaten human lives in case of failure or malfunction of the product or may cause harm to human bodies, nor shall they grant any guarantee thereof. If you should intend to use our products for applications outside the standard applications of our customer who is considering such use and/or outside the scope of our intended standard applications, please consult with us prior to the intended use. If there is no consultation or inquiry before the intended use, our customer shall be solely responsible for the use.
- Specifications of any and all SANYO Semiconductor Co.,Ltd. products described or contained herein stipulate the performance, characteristics, and functions of the described products in the independent state, and are not guarantees of the performance, characteristics, and functions of the described products as mounted in the customer's products or equipment. To verify symptoms and states that cannot be evaluated in an independent device, the customer should always evaluate and test devices mounted in the customer's products or equipment.
- SANYO Semiconductor Co.,Ltd. assumes no responsibility for equipment failures that result from using products at values that exceed, even momentarily, rated values (such as maximum ratings, operating condition ranges, or other parameters) listed in products specifications of any and all SANYO Semiconductor Co.,Ltd. products described or contained herein.
- SANYO Semiconductor Co.,Ltd. strives to supply high-quality high-reliability products, however, any and all semiconductor products fail or malfunction with some probability. It is possible that these probabilistic failures or malfunction could give rise to accidents or events that could endanger human lives, trouble that could give rise to smoke or fire, or accidents that could cause damage to other property. When designing equipment, adopt safety measures so that these kinds of accidents or events cannot occur. Such measures include but are not limited to protective circuits and error prevention circuits for safe design, redundant design, and structural design.
- In the event that any or all SANYO Semiconductor Co.,Ltd. products described or contained herein are controlled under any of applicable local export control laws and regulations, such products may require the export license from the authorities concerned in accordance with the above law.
- No part of this publication may be reproduced or transmitted in any form or by any means, electronic or mechanical, including photocopying and recording, or any information storage or retrieval system, or otherwise, without the prior written consent of SANYO Semiconductor Co.,Ltd.
- Any and all information described or contained herein are subject to change without notice due to product/technology improvement, etc. When designing equipment, refer to the "Delivery Specification" for the SANYO Semiconductor Co.,Ltd. product that you intend to use.
- Information (including circuit diagrams and circuit parameters) herein is for example only; it is not guaranteed for volume production.
- Upon using the technical information or products described herein, neither warranty nor license shall be granted with regard to intellectual property rights or any other rights of SANYO Semiconductor Co.,Ltd. or any third party. SANYO Semiconductor Co.,Ltd. shall not be liable for any claim or suits with regard to a third party's intellectual property rights which has resulted from the use of the technical information and products mentioned above.

This catalog provides information as of June, 2011. Specifications and information herein are subject to change without notice.